

Temperature Measurement of Ladle Preheater

Problem:

Mechanical or electrical failure creating maintenance headaches.
Inaccurate temperature control because the thermocouple measures the air inside of the ladle rather than the ladle refractory temperature.

Solution:

Proper control of refractory preheat temperature prevents refractory cracking from thermal shock, extends refractory life, optimizes molten metal temperatures for desired metallurgy, and maximizes energy efficiency. The use of a Fiber Optic, two-color pyrometer to measure the ladle refractory temperature enables true refractory temperature measurement.

Equipment:

- PM-100-2C-FO, Infrared Pyrometer

Features:

- Non contact
- Accuracy
- Safety
- Easy installation
- Reduce maintenance
- Increase uptime
- Increase lifespan of the ladle

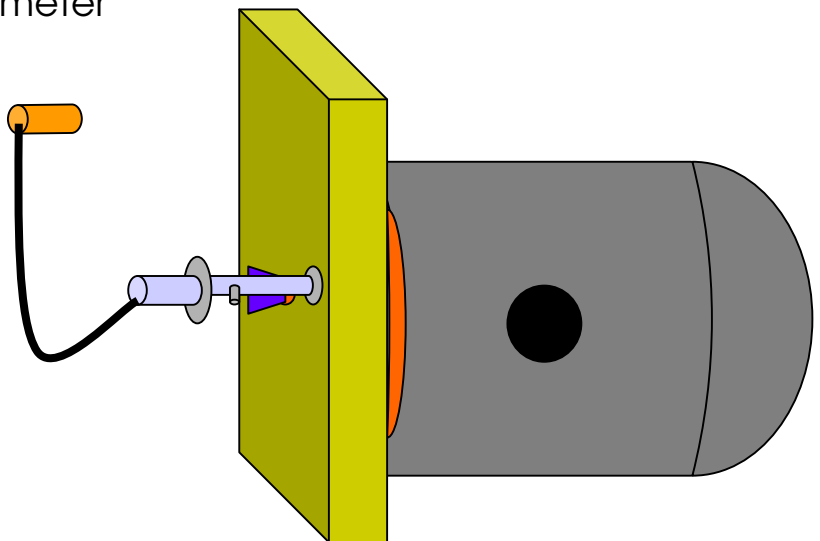

Benefits:

Tens of thousand dollars per year, per preheat station, in thermocouples usage.

Quick pay back.